

**380TVL IP Camera
CAM-5100M & CAM-5100S
User's Manual**

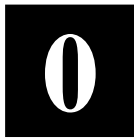

www.acti.com



PRECAUTIONS

1. Read these instructions

All the safety and operating instructions should be read before the product is operated.

2. Heed all warnings

All warnings on the product and in the instruction manual should be adhered to.



The symbol indicates the following items, please carefully read the description next to each symbol.

- a. Failure to follow the safety instruction given may directly endanger people, cause damage to the system or to other equipment.
- b. The requirements to make this device work, including hardware, computer settings, network settings, and operation procedures.
- c. The tips to make using this device easier, more convenient and more efficient.

3. Servicing

Do not attempt to service this video product yourself as opening or removing covers may expose you to dangerous voltage or other hazards. Refer all servicing to qualified service personnel.

Copyright

This manual is the intellectual property of ACTi and is protected by copyright. All rights are reserved. No part of this document may be reproduced or transmitted for any purpose by any means including electronic or mechanical without the official written permission from ACTi.

Trademarks

All names used in this manual for hardware and software are probably registered trademarks of respective companies.

Liability

Every care has been taken during writing this manual. Please inform your local office if you find any inaccuracies or omissions. We cannot be held responsible for any

typographical or technical errors and reserve the right to make changes to the product and manuals without prior notice.

FCC/CE Regulation

NOTE: This equipment has been tested and found to comply with the limits for a Class A digital device, pursuant to Part 15 of the FCC Rules. These limits are designed to provide reasonable protection against harmful interference when the equipment is operated in a commercial environment. This equipment generates, uses, and can radiate radio frequency energy and, if not installed and used in accordance with the instruction manual, may cause harmful interference to radio communications. Operation of this equipment in a residential area is likely to cause harmful interference in which case the user will be required to correct the interference at his own expense.

FCC Caution: To assure continued compliance, (example – use only shielded interface cables when connecting to computer or peripheral devices). Any changes or modifications not expressly approved by the party responsible for compliance could void the user's authority to operate this equipment.

CE: This device passed the test performed according to the European standard EN55022:1998 Class A, EN 61000-3-2:2000, EN61000-3-3”1995/A1:2001, EN55024:1998/A1:2001.

Table of Contents

0	<i>PRECAUTIONS</i>	<i>0-1</i>
	Copyright	0-1
	Trademarks	0-1
	Liability	0-1
	FCC/CE Regulation	0-2
1	<i>INTRODUCTION</i>	<i>1-1</i>
1.1	PACKAGE CONTENTS	1-1
1.2	FEATURES AND BENEFITS	1-2
1.3	SAFETY INSTRUCTIONS	1-4
1.4	MINIMUM SYSTEM REQUIREMENTS	1-5
1.5	PARTS' NAMES AND LOCATIONS	1-6
1.5.1	RS-485 Pin Assignment.....	1-9
2	<i>INSTALLATION</i>	<i>2-1</i>
2.1	BASIC CONNECTIONS	2-1

1

INTRODUCTION

1.1 PACKAGE CONTENTS

CAM-5100M/S



Software CD



Warranty Card

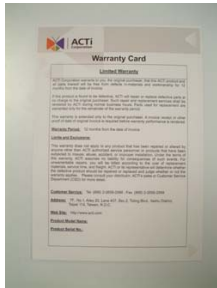

Terminal Blocks for DI/O



Power Adaptor



Accessory



1.2 FEATURES AND BENEFITS

The IP Camera is a cutting-edge digital video transmission device. It can compress and transmit real time images with outstanding images quality at reasonable bandwidth through a standard TCP/IP network. That's because it is Ethernet (LAN and WAN) ready and has the powerful ARM9 SoC and the MPEG-4 compression ASIC inside. In addition, with these powerful hardware platform, excellent SDK support and powerful respective apparatuses (ex: the transcoder), this IP Camera is your best choice building up either conventional IP surveillance system or intelligent IP surveillance system.

- **Real-time MPEG-4 Compression**

With Hardware MPEG-4 compression chip inside, the composite video inputs can be efficiently compressed into MPEG-4 bit stream without any delay. The ASIC base compression engine can support CIF resolution.

- **QoS Enabled Video Streaming**

For real-time video streaming requirements, the IP camera implemented the 802.1pQ features inside the SoC as the streaming engine to make sure the video streaming package is forwarded faster than normal TCP/UDP packet.

- **Automatic Frame Rate Control**

The IP Camera supports automatic/manual streaming frame rate control, especially for multiple clients concurrent access the same video stream in different network bandwidth.

- **Digital Time Code Embedded**

The "Digital Time Code Embedded" function is to embed the recording time in the MPEG bit stream. Therefore, each image frame has its respective time when it was recorded. It is very useful when users want to find the video at an exact time or between a certain time intervals.

- **Build-in LAN and WAN (Low Latency PPPoE Supported) Ports**

The IP Camera provides two RJ-45 connectors. One is WAN and the other is LAN. The WAN port connects to the internet and LAN port connects to the local network. Since the internet's bandwidth is very critical, the WAN port is equipped with a low latency PPPoE

(Point-to-Point over Ethernet) which has excellent transmission speed and enables the IP Camera to connect to an ADSL or a cable modem.

- **DDNS Supported**

The IP Camera supports DDNS (Dynamic Domain Name Server), users can set the IP Camera at a virtual domain name (such as cam1.Taipei.xxx) at dynamic IP. Everyone can use the virtual domain name to view the video anywhere that has the access to the internet.

- **Build-in Hardware Motion Detection**

No more external motion sensors are required. Each IP Camera can be set up to 3 detection areas. By tuning the object size and sensitivity, it is very reliable to fit into your environment. Besides, hardware motion detection delivers better sensitivity and respond faster than software motion detection.

- **Bundle Powerful Surveillance Software**

To extend the capabilities of the IP Camera, a powerful surveillance program is included in the package and is totally free to use. Users can easily utilize the existing PC to be a digital video recorder. Schedule recording and manual recording keep every important image recorded in the local hard disk. Reliable and accurate motion detection with instant warning makes you responsive in every condition. Quick and simple search and playback function lets you easily find the images you want.

- **Software Development Kit Support**

The IP Camera can be integrated or controlled by user's application program through the Streaming Library or ActiveX control. With its high level programming interface, software developer's time and efforts to is highly reduced.

1.3 SAFETY INSTRUCTIONS

- **Don't use the power supply with other voltages**

This device is likely to be damaged or damage other equipments / personnel, if you use a power supply with different voltage than the one included with this device. All warranty of this product will be voided in the situations above.

- **Don't open the housing of the product**

- **Cleaning**

Disconnect this video product from the power supply before cleaning.

- **Attachments**

Do not use attachments not recommended by the video product manufacturer as they may cause hazards.

- **Water and Moisture**

Do not use this video product near water, for example, near a bathtub, washbowl, kitchen sink, or laundry tub, in a wet basement, or near a swimming pool and the like.

- **Don't use accessories not recommended by the manufacturer**

- **Only install this device and the power supply in a dry place protected from weather**

- **Servicing**

Do not attempt to service this video product yourself as opening or removing covers may expose you to dangerous voltage or other hazards. Refer all servicing to qualified service personnel.

- **Damage Requiring service**

Disconnect this video product from the power supply immediately and refer servicing to qualified service personnel under the following conditions.

1. When the power-supply cord or plug is damaged.
2. If liquid has been spilled, or objects have fallen into the video product.
3. If the video product has been exposed to rain or water directly.
4. If the video product does not operate normally by following the

operating Instructions in this manual. Adjust only those controls that are covered by the instruction manual as an improper adjustment . Other controls may result in damage and will often require extensive work by a qualified technician to restore the video product to its normal operation.

- **Safety Check**

Upon completion of any service or repairs to this video product, ask the service technician to perform safety checks to determine that the video product is in proper operating condition.

1.4 MINIMUM SYSTEM REQUIREMENTS

CPU	Pentium 4 2.4GHz and above
Hard Disk	40 GB or above
Memory	256 MB or above
Operating System	Windows XP / Windows 2000 with SP4 or above
Required Utilities	FFDShow, DirectX 9.0b or later hardware acceleration
Video Resolution	SVGA or XGA with 1024x768 resolution, 32-bit color

1.5 PARTS' NAMES AND LOCATIONS



1. **DI/O**
The IP Camera supports one alarm input and one alarm output.
DI:Logic Level 0: 0~0.8V; Logic Level 1: 2.31~5.3V
DO:Logic Level 0: 0~0.5V; Logic Level1: 2.8~3.3V
2. **Power LED Indicator**
3. **Power**
12V 1.5A DC jack input.
4. **LAN port**
The IP Camera connects to the LAN (local area network) via a standard RJ45 connector. Supporting NWAY, this IP camera can auto detect the speed of local network segment (10Base-T/100Base-TX Ethernet).
5. **Analog Video Output**
The IP Camera supports one channel analog video output.
6. **WAN port**
The IP Camera connects to the WAN (wide area network) via a standard RJ45 connector. Supporting NWAY, this IP camera can auto detect the speed of local network segment (10Base-T/100Base-TX Ethernet). The WAN port is for FTTH and can connect to a xDSL or cable modem.

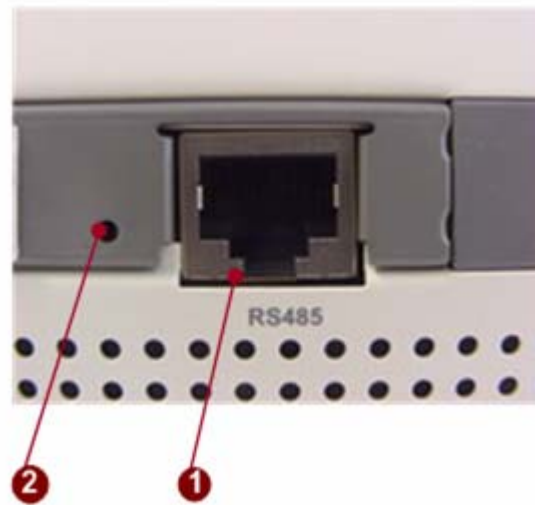

1. **RS485 port**

The IP Camera can control or communicate with external devices via this RS485 port with RJ45 connector. Please refer to the Pin assignment reference 1.5.1. at Page 1-9.

2. **Reset button**

Step 1: Switch off IP camera by disconnecting the power cable

Step 2: Using a suitable pointed object, press and continue to hold the Reset Button depressed. While continuing to hold the reset button depressed, reconnect the power cable.

Step 3: Keep holding the reset button depressed around 6 seconds, release the reset button. The unit will start up with factory default settings.

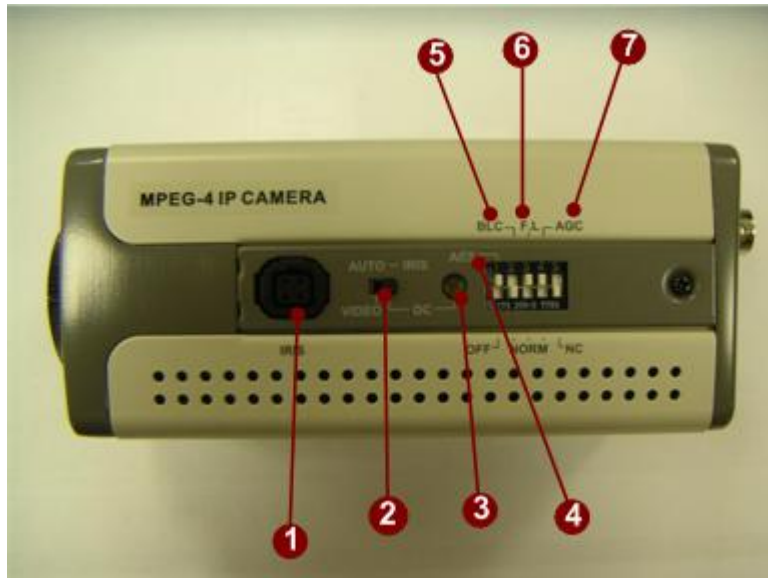

1. **Auto IRIS Output**
2. **Auto IRIS Control**
Video / DC (Switchable)
3. **Video DC Level Adjustment**
4. **Auto Electronic Shutter**
AES OnL 1/50 (60) sec. ~ 1/100,000 sec;
AES Off: 1/50 (60) sec.
5. **Back Light Compensation**
On / Off (Switchable)
6. **Flickerless**
On / Off (Switchable)
7. **Automatic Gain Control**
On / Off (Switchable)

1.5.1 RS-485 Pin Assignment

RJ-45 Connector Pin Assignment for RS-485

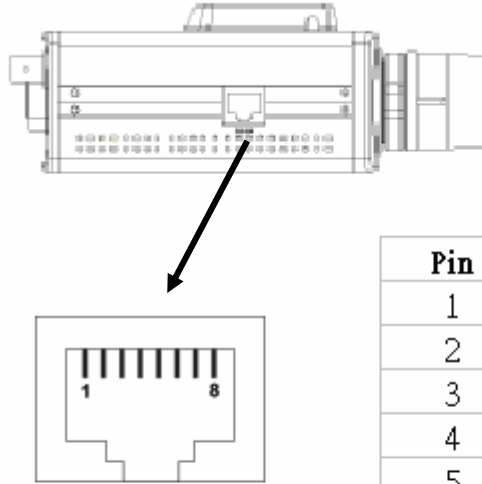

Pin	RS-485
1	GND
2	D-
3	D+
4	GND
5	GND
6	-
7	-
8	GND

RS-485 Cable Pin Assignment



P8.....P1

Pin	RS-485
1	GND
2	D-
3	D+
4	GND
5	GND
6	-
7	-
8	GND

2

INSTALLATION

2.1 BASIC CONNECTIONS

Follow the procedures below to connect the IP camera to the respective apparatuses. Please refer to page 1-6 for more details.

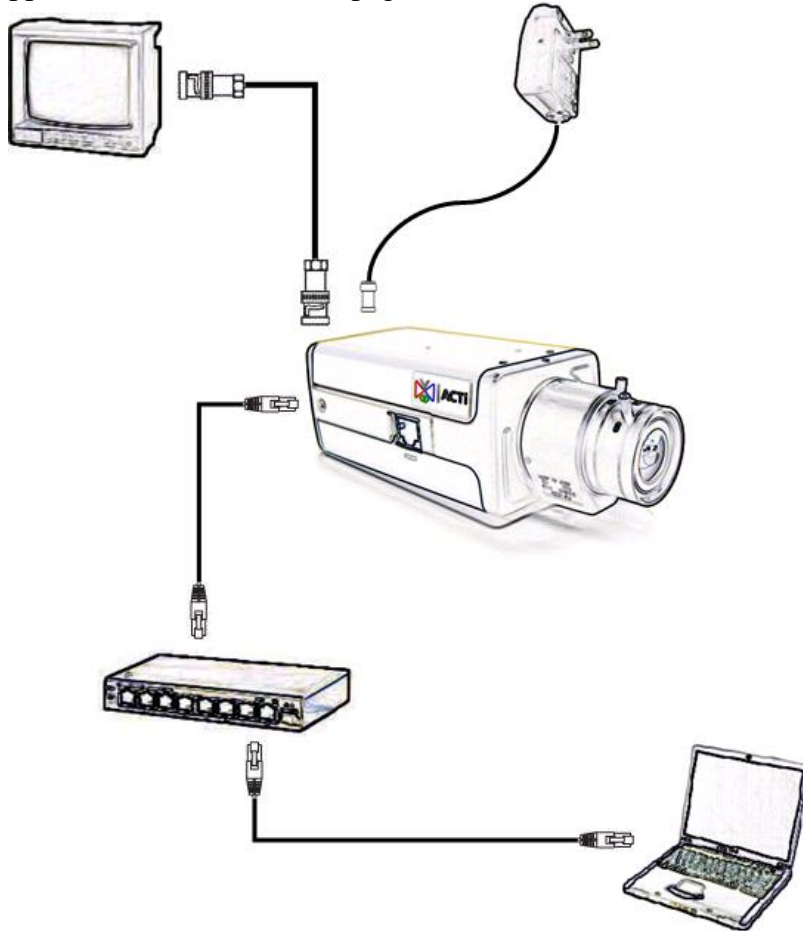

1. Connect an analog monitor to IP Camera video out (BNC connector).
2. Connect the power adaptor to IP Camera
3. Connect IP Camera's LAN port to an Ethernet (RJ45 connectors)
4. Connect a PC to the Ethernet hub (RJ45 connectors)



NOTE: Software installation please refers to Software user manual.